

# Raybestos 6-piston short track/road course front package



## CALIPERS

|   |   |
|---|---|
| <b>PC1003L/R</b><br>1.38" (35 mm) Rotor |  |
| <b>PC1005L/R</b><br>1.65" (42 mm) Rotor |   |

**PHK4006**  
Conversion Kit  
from 1.38" to  
1.65" Rotor

**PHK4007**  
Conversion Kit  
from 1.65" to  
1.38" Rotor

## PADS

**Raybestos-R600**  
30 mm

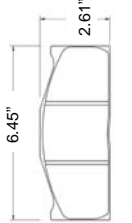

## ROTORS

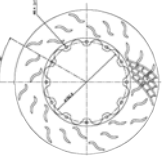
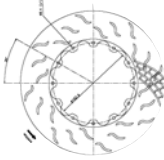
|   |   |
|---|---|
| <p><b>PR2003L/R</b><br/>12.91" X 1.38"<br/>(328 mm X 35 mm)<br/>252 Vane<br/>12 x 7.2" Bolt Circle</p>  | <p><b>PR2005L/R</b><br/>12.91" X 1.65"<br/>(328 mm X 42 mm)<br/>48 Vane<br/>12 x 7.2" Bolt Circle</p>  |
|---|---|

## HATS

|   |  |
|---|--|
| <p><b>PRH3007</b><br/>1.68" (42 mm) Offset</p> <p><b>PRH3004</b><br/>1.81" (46 mm) Offset</p> <p><b>PRH3003</b><br/>1.94" (49 mm) Offset</p> <p><b>PRH3005</b><br/>2.09" (53 mm) Offset</p> |  |
|---|--|

**PHK4000**  
Hardware Kit  
Bobbins, Bolts, & Nuts  
(12 Each Per Hat)

## HARDWARE

## service parts

- 41.3 mm piston
- 34.9 mm piston
- 30.2 mm piston
- caliper seal kit
- 210 mm bracket

- PHK4015** bridge pipe
- PHK4012** bleed screw kit
- PHK4010**
- PHK4002**
- PBC5002**

- PHK4023**
- PHK4005**

**Brake Parts, Inc. (Raybestos)**  
T +1 (615) 896-6774  
F 1+ (615) 895-2901  
E ron.sledge@affinagroup.com  
Contact: Ron Sledge

**Alcon USA (Technical Support)**  
T +1 (704) 799-2723  
F +1 (704) 799-2287  
E jthomas@alconusa.com  
Contact: Jerry Thomas



# information



## Raybestos short track/road course front package

### options

- 1.375" (35 mm) and 1.625" (42 mm) rotor options.

### features and benefits

- Six piston staggered bore design for better pedal feel and reduced pad taper.
- Web bridge design for superior stiffness and minimal lateral deflection; improves release characteristics.
- Rib protects bleed screws and bridge pipe during tire change.
- Superior pad retraction for minimal rotor drag.
- Premium, high temperature aluminum alloy monobloc.
- Standard 210 mm radial mount.
- Large pad area and volume; widely available pad shape.
- Ventilated piston inserts, optional heights.
- High temperature seals.



### specifications

|   |   |
|---|---|
| <b>Piston size</b>                      | 41.3/34.9/30.2 mm<br>(1.625"/1.375"/1.188") |
| <b>Pad thickness</b>                    | 30 mm                                       |
| <b>High airflow rotors</b>              |   |
| • 42 mm, 48 vane "turbulator" rotor     | 19.25 lbs. (8.73 kg)                        |
| • 35 mm, 252 vane rotor                 | 17.9 lbs. (8.12 kg)                         |
| <b>PC1003/PC1005 front caliper</b>      | 7.3 lbs. (3.3 kg)                           |
| <b>Bobbin drive hat</b>                 | 2.30 lbs. (1.04 kg)                         |
| <b>Bobbin drive hardware (axle set)</b> | 1.21 lbs. (0.55 kg)                         |

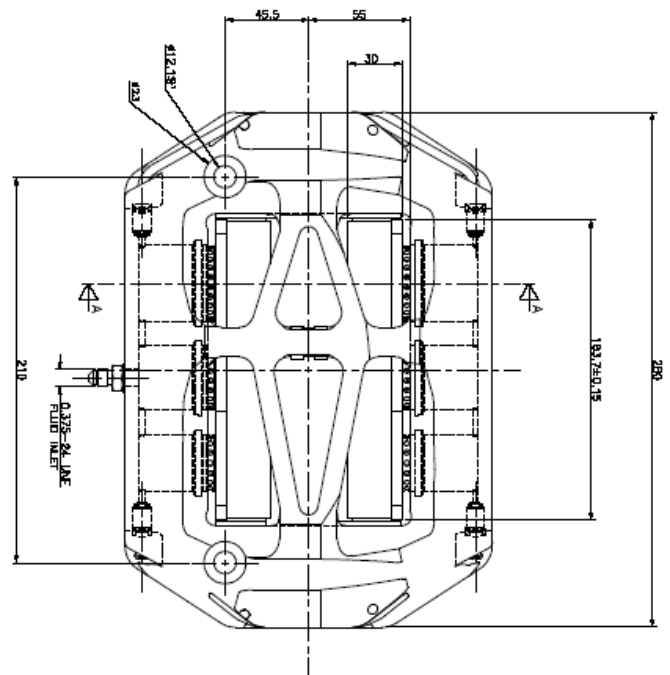

### applications

NASCAR Nextel Cup, Busch Series and Craftsman Truck Series.