

Raybestos 4-piston intermediate & superspeedway rear package





HARDWARE

HATS

ROTORS

PADS

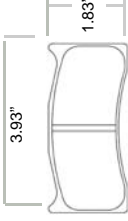
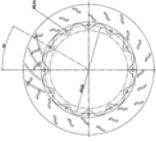
CALIPERS

<p>PC1002L/R 1" (25 mm) Rotor</p> 	<p>Raybestos-R736 20 mm</p> 	<p>PR2002L/R 12" X 1" (305 mm x 25 mm) 24 Vane 12 x 8.1" Bolt Circle</p> 	<p>PRH3002 1.68" (42 mm) Offset</p> <p>PRH3001 1.85" (47 mm) Offset</p> <p>PRH3006 1.929" (49 mm) Offset</p> <p>PRH3000 2.12" (54 mm) Offset</p> 	<p>PHK4000 Hardware Kit Bobbins, Bolts, & Nuts (12 Each Per Hat)</p>
--	--	--	---	---

service parts

1.18" (30mm) piston	PHK4009	bridge pipe left	PHK4016	Alcon USA (Technical Support)
1.06" (27 mm) piston	PHK4008	bridge pipe right	PHK4017	T +1 (704) 799-2723
Caliper seal kit	PHK4001	bleed screw kit	PHK4005	F +1 (704) 799-2287
120 mm Bracket	PBC5003			E jthomas@alconusa.com
				Contact: Jerry Thomas



information



Raybestos intermediate & superspeedway rear package

options

- 1.00" (25 mm) rotor option.

features and benefits

- Web bridge design for superior stiffness and minimal lateral deflection; improves release characteristics.
- Rib protects bleed screws and bridge pipe during tire change.
- Superior pad retraction for minimal rotor drag.
- Standard 120 mm radial mount.
- Ventilated piston inserts.
- O-ring sealed bleed screws prevents air ingress and fluid loss.
- Easily installed and unique pad retraction springs mounted on bridge
- Stainless steel wear plates and pad abutments.



specifications

Piston size	30.2/ 27 mm (1.18"/ 1.06")
Pad thickness	20 mm
High airflow rotors	
• 25 mm , 252 vane rotor	8 lbs. (3.6 kg)
PC1002 rear caliper	4.4 lbs. (2 kg)
Bobbin drive hat	2.30 lbs. (1.04 kg)
Bobbin drive hardware (axle set)	1.21 lbs. (0.55 kg)

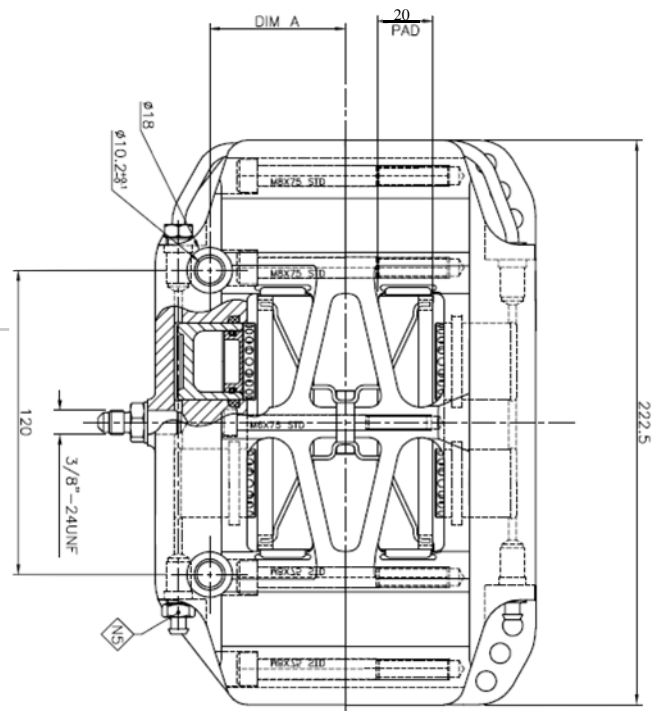

applications

NASCAR Nextel Cup, Busch Series and Craftsman Truck Series.