

Raybestos 4-piston heavy intermediate rear package



HARDWARE

HATS

ROTORS

PADS

CALIPERS

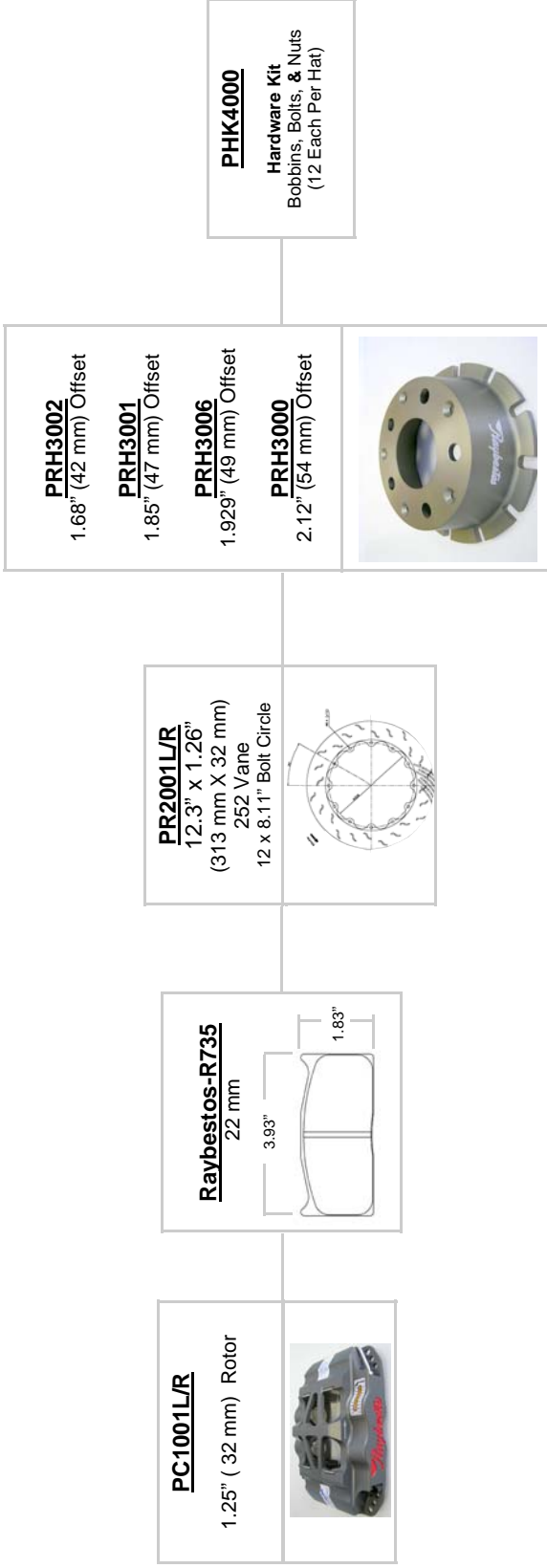

service parts

- 1.18" (30.2 mm) piston **PHK4009**
- 1.06" (27 mm) piston **PHK4008**
- caliper seal kit **PHK4001**
- 120 mm bracket **PBC5001**
- bridge pipe left **PHK4018**
- bridge pipe right **PHK4019**
- bleed screw kit **PHK4005**

Alcon USA (Technical Support)
T +1 (704) 799-2723
F +1 (704) 799-2287
E jthomas@alconusa.com
Contact: Jerry Thomas

Brake Parts, Inc. (Raybestos)
T +1 (615) 896-6774
F +1 (615) 895-2901
E ron.sledge@affinagroup.com
Contact: Ron Sledge



information



Raybestos heavy intermediate rear package

options

- 1.26" (32 mm) rotor option.

features and benefits

- Web bridge design for superior stiffness and minimal lateral deflection; improves release characteristics.
- Rib protects bleed screws and bridge pipe during tire change.
- Superior pad retraction for minimal rotor drag.
- Standard 120 mm radial mount.
- Ventilated piston inserts.
- O-ring sealed bleed screws prevents air ingress and fluid loss.
- Stainless steel wear plates and pad abutments.



specifications

Piston size	30.2/ 27 mm (1.18"/ 1.06")
Pad thickness	22 mm
High airflow rotors	
• 32 mm , 252 vane rotor	11.3 lbs. (5.12 kg)
PC1001 rear caliper	4.4 lbs. (2 kg)
Bobbin drive hat	2.30 lbs. (1.04 kg)
Bobbin drive hardware (axle set)	1.21 lbs. (0.55 kg)

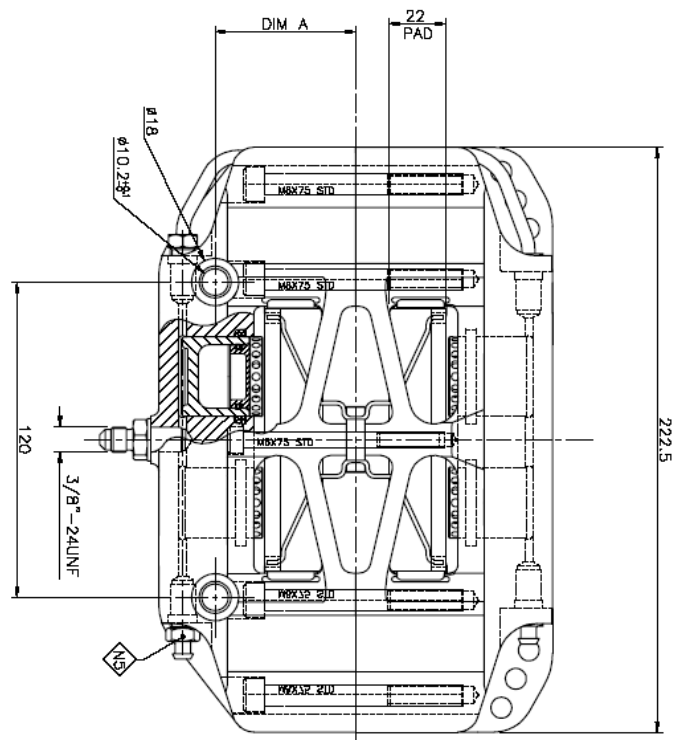

applications

NASCAR Nextel Cup, Busch Series and Craftsman Truck Series.