



rod ends and spherical bearings

R A C I N G S E R I E S





Table of Contents

NHBB offers a full line of race-proven rod ends and sphericals for your most demanding, high performance racing applications.

Our worldwide leadership in aerospace bearing products has given us a wealth of technological experience and expertise that, along with our strict adherence to quality control standards, enable us to meet the challenging requirements of today's racing industry.

If you're looking for strength, durability, and consistent World-Class performance in high-stress racing conditions, you can rely on NHBB to deliver—lap after lap, mile after mile.

ROD END BEARINGS

<u>ART-ECR, ART-CR, AKNE</u>	<u>3-piece, TEFLON® Lined</u>	<u>2</u>
<u>ARHT-ECR, ARHT-CR</u>	<u>3-piece, TEFLON® Lined, Heavy Duty</u>	<u>3</u>
<u>ARYT-ECR, ARYT-CR</u>	<u>3-piece, TEFLON® Lined, High Misalignment</u>	<u>4</u>

SPHERICAL BEARINGS

<u>ABT, ABT-V, ATB</u>	<u>TEFLON® Lined, Narrow</u>	<u>5</u>
<u>ABWT, ABWT-V</u>	<u>TEFLON® Lined, Wide</u>	<u>6</u>
<u>ABYT, ABYT-V</u>	<u>TEFLON® Lined, High Misalignment</u>	<u>7</u>

<u>STAKING PROCEDURE</u>	<u>8</u>
<u>MISALIGNMENT ANGLE</u>	<u>9</u>
<u>INTERCHANGE CHART</u>	<u>9</u>

Note: NHBB reserves the right to change specifications and other information included in this catalog without notice. All information, data and dimension tables in this catalog have been carefully compiled and thoroughly checked. However, no responsibility for possible errors or omissions can be assumed.
TEFLON® is a Du Pont registered trademark

ROD END BEARINGS

ART-ECR, ART-CR, AKNE

3-piece, TEFLON® Lined, Male and Female Threads

Note:

For left hand threads, add "L" to prefix.
Example: ARTL3ECR

ART-ECR

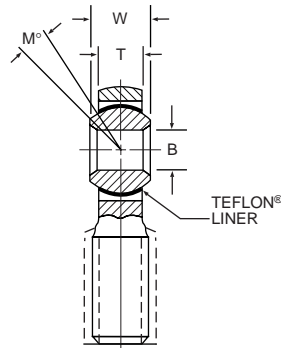
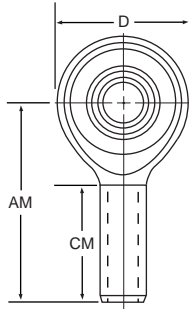

ART-CR

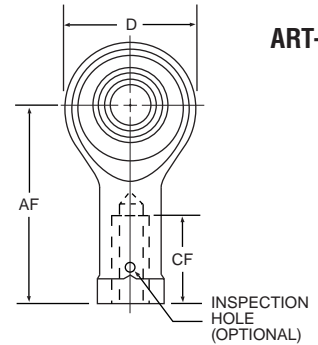

BASIC P/N	BORE X THD. SIZE REF.	# OF THDS.	(B)	(D)	(W)	(T)	(AM)	(AF)	(CM)	(CF)	(M°)	ULT. STATIC RADIAL LOAD LBS.	NO LOAD ROTATIONAL BREAKAWAY TORQUE IN./LBS.	APPROX. WEIGHT LBS.
			DIA. +.0000 -.0005	HEAD DIA. +/- .010	BALL WIDTH +.000 -.002	BODY WIDTH +/- .005	LGTH. C/L TO END +/- .010	LGTH. C/L TO END +/- .010	THREAD LGTH. +/- .031	THREAD LGTH. MIN.	MIS-ALIGN. REF.			
ART3ECR ART3CR	3/16 x 5/16	24	.1900	.806	.437	.337	1.562	1.375	.968	.750	15	2,360	.5-6	.072 .080
ART4ECR ART4CR	1/4 x 5/16	24	.2500	.806	.437	.337	1.562	1.469	.968	.750	15	4,860	.5-6	.072 .084
AKNE4-4024	1/4 x 1/4	28	.2500	.806	.437	.337	1.562	1.469	.968	.750	15	7,200	.5-6	.070
ART5ECR ART5CR	5/16 x 5/16 5/16 x 3/8	24 24	.3125	.900	.437	.327	1.875	1.625	1.187	.875	14	7,180	1-10	.087 .102
ART6ECR ART6CR	3/8 x 3/8	24	.3750	1.025	.500	.416	1.938	1.812	1.187	1.000	8	8,550	1-10	.136 .161
ART7ECR ART7CR	7/16 x 7/16	20	.4375	1.150	.562	.452	2.125	2.000	1.281	1.125	10	12,000	1-10	.183 .212
ART8ECR ART8CR	1/2 x 1/2	20	.5000	1.337	.625	.515	2.438	2.250	1.468	1.250	9	19,500	1-10	.278 .325
ART10ECR ART10CR	5/8 x 5/8	18	.6250	1.525	.750	.577	2.625	2.500	1.562	1.375	12	21,900	1-10	.424 .481
ART12ECR ART12CR	3/4 x 3/4	16	.7500	1.775	.875	.640	2.875	2.875	1.687	1.625	13	29,300	1-10	.639 .673
ART14ECR ART14CR	7/8 x 7/8	14	.8750	2.025	.875	.765	3.375	3.375	2.000	1.875	6	34,500	2-16	.963 .959
ART16ECR ART16CR	1 x 1-1/4	12	1.0000	2.775	1.375	1.015	4.125	4.125	2.343	2.125	12	80,300	2-16	2.546 2.717

Materials

DESIGNATION	BALL	LINER	RACE/BODY
ART-ECR	440C CRES	TEFLON® fabric	17-4PH CRES
ART-CR	heat treated	permanently bonded	heat treated
AKNE		to race I.D.	

TEFLON® is a Du Pont registered trademark



ARHT-ECR, ARHT-CR

**3-piece, TEFLON® Lined, Heavy Duty
Male and Female Threads**

Note:

For left hand threads, add "L" to prefix.
Example: ARHTL4ECR

ARHT-ECR

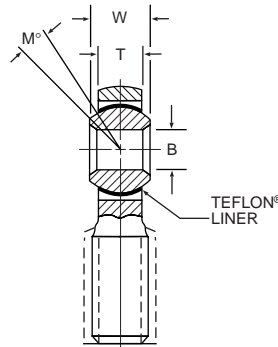
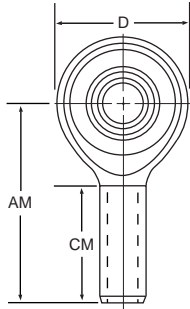

ARHT-CR

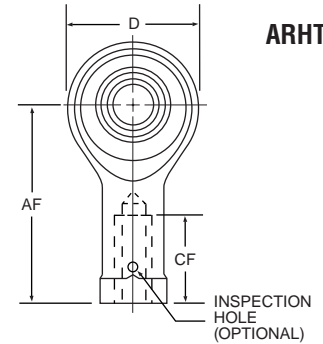

BASIC P/N	BORE X THD. SIZE REF.	# OF THDS.	(B)	(D)	(W)	(T)	(AM)	(AF)	(CM)	(CF)	(M°)	ULT. STATIC RADIAL LOAD LBS.	NO LOAD ROTATIONAL BREAKAWAY TORQUE IN./LBS.	APPROX. WEIGHT LBS.
			DIA. +.0000 -.0005	HEAD DIA. +/- .010	BALL WIDTH +.000 -.002	BODY WIDTH +/- .005	LGTH. C/L TO END +/- .010	LGTH. C/L TO END +/- .010	THREAD LGTH. +/- .031	THREAD LGTH. MIN.	MIS-ALIGN. REF.			
ARHT4ECR ARHT4CR	1/4 x 5/16	24	.2500	.806	.375	.337	1.562	1.469	.968	.750	5	7,100	.5-6	.067 .084
ARHT5ECR ARHT5CR	5/16 x 3/8	24	.3125	.900	.437	.327	1.875	1.625	1.187	.875	14	8,600	1-10	.095 .102
ARHT6ECR ARHT6CR	3/8 x 7/16	20	.3750	1.025	.500	.416	1.938	1.812	1.187	1.000	9	10,100	1-10	.140 .160
ARHT7ECR ARHT7CR	7/16 x 1/2	20	.4375	1.150	.562	.452	2.125	2.000	1.281	1.125	10	11,000	1-10	.210 .230
ARHT8ECR ARHT8CR	1/2 x 5/8	18	.5000	1.337	.625	.515	2.438	2.250	1.468	1.250	9	21,800	1-10	.330 .340
ARHT10ECR ARHT10CR	5/8 x 3/4	16	.6250	1.525	.750	.577	2.625	2.500	1.562	1.375	12	24,300	1-10	.480 .490
ARHT12ECR ARHT12CR	3/4 x 7/8	14	.7500	1.775	.875	.640	2.875	2.875	1.687	1.625	13	32,200	1-10	.730 .740

Materials

DESIGNATION	BALL	LINER	RACE/BODY
ARHT-ECR ARHT-CR	440C CRES heat treated	TEFLON® fabric permanently bonded to race I.D.	17-4PH CRES heat treated

TEFLON® is a Du Pont registered trademark

ROD END BEARINGS

ARYT-ECR, ARYT-CR

3-piece, TEFLON® Lined, High Misalignment
Male and Female Threads

Note:

For left hand threads, add "L" to prefix.
Example: ARYTL3ECR

ARYT-ECR

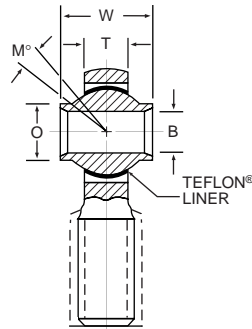
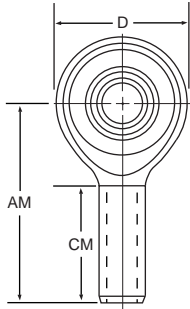

ARYT-CR

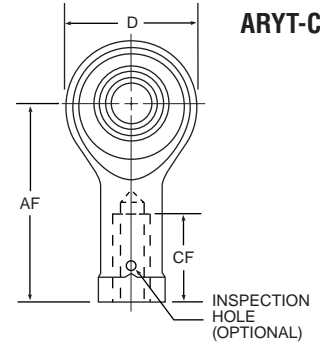

BASIC P/N	BORE X THD. SIZE REF.	# OF THDS.	(B)	(D)	(W)	(T)	(O)	(AM)	(AF)	(CM)	(CF)	(M°)	ULT. STATIC RADIAL LOAD LBS.	NO LOAD ROTATIONAL BREAKAWAY TORQUE IN./LBS.	APPROX. WEIGHT LBS.
			DIA. +.0000 -.0005	HEAD DIA. +/- .010	BALL WIDTH +.000 -.005	BODY WIDTH +/- .005	SHOULDER DIA. REF.	LGTH. C/L TO END +/- .031	LGTH. C/L TO END +/- .031	THREAD LGTH. +/- .031	THREAD LGTH. MIN.	MIS-ALIGN. REF.			
ARYT3ECR ARYT3CR	3/16 x 5/16	24	.1900	.750	.500	.220	.319	1.500	1.375	1.000	.700	13	4,830	.5-6	.073 .062
ARYT4ECR ARYT4CR	1/4 x 3/8	24	.2500	1.000	.593	.265	.390	1.938	1.625	1.250	.887	23	8,650	.5-6	.107 .107
ARYT5ECR ARYT5CR	5/16 x 7/16	20	.3125	1.125	.813	.355	.512	2.125	1.812	1.375	1.012	22	9,050	1-15	.161 .184
ARYT6ECR ARYT6CR	3/8 x 7/16	20	.3750	1.125	.813	.355	.512	2.125	1.812	1.375	1.012	22	9,050	1-15	.152 .171
ARYT7ECR ARYT7CR	7/16 x 1/2	20	.4375	1.312	.875	.355	.618	2.438	2.125	1.500	1.075	21	14,100	1-15	.249 .269
ARYT8ECR ARYT8CR	1/2 x 5/8	18	.5000	1.500	.937	.411	.730	2.625	2.625	1.625	1.450	19	19,800	1-15	.391 .400
ARYT10ECR ARYT10CR	5/8 x 3/4	16	.6250	1.750	1.200	.577	.856	2.875	2.875	1.750	1.700	19	26,500	1-15	.621 .633
ARYT12ECR ARYT12CR	3/4 x 7/8	14	.7500	2.000	1.280	.630	.970	3.375	3.375	1.875	1.825	18	34,200	1-24	.900 .869
ARYT14ECR ARYT14CR	7/8 x 7/8	14	.8750	2.200	1.400	.635	1.140	3.750	3.750	2.000	1.950	17	36,400	1-24	1.080 1.010
ARYT16ECR ARYT16CR	1 x 1-1/4	12	1.0000	2.750	1.875	.845	1.278	4.125	4.125	2.125	2.075	20	66,500	1-24	2.200 2.313
ARYT20ECR ARYT20CR	1-1/4 x 1-1/4	12	1.2500	3.125	1.875	1.015	1.523	5.000	5.000	2.875	3.075	20	80,000	1-24	3.100 3.154

Materials

DESIGNATION	BALL	LINER	RACE/BODY
ARYT-ECR ARYT-CR	440C CRES heat treated	TEFLON® fabric permanently bonded to race I.D.	17-4PH CRES heat treated

TEFLON® is a Du Pont registered trademark



ABT, ABT-V, ATB

TEFLON® Lined, Narrow

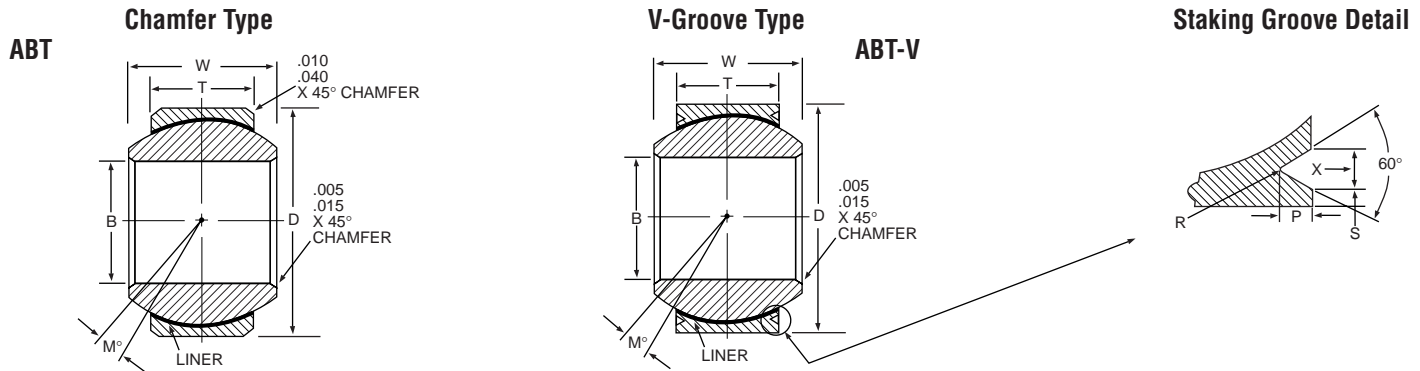

BASIC P/N	(B)	(D)	(W)	(T)	(M°)	ULT. STATIC RADIAL LOAD LBS.	ULT. STATIC AXIAL LOAD LBS.	NO LOAD ROTATIONAL BREAKAWAY TORQUE IN./LB.	APPROX. WEIGHT LBS.
	BORE DIA. +.0000 -.0005	OUTSIDE DIA. +.0000 .0005	BALL WIDTH +.000 -.002	RACE WIDTH +/- .005	MIS-ALIGN. MIN.				
ABT3 ABT3V	.1900	.5625	.281	.218	10	5,962	225	.25-8	.020
ABT4 ABT4V	.2500	.6562	.343	.250	10	9,060	645	.25-8	.020
ABT5 ABT5V	.3125	.7500	.375	.281	10	13,125	1,050	.25-8	.030
ABT6 ABT6V	.3750	.8125	.406	.312	9	15,810	1,650	.25-8	.040
ABT7 ABT7V	.4375	.9062	.437	.343	8	19,800	2,100	.25-8	.050
ATB8-4001	.5005	.8750	.437*	.375	6	24,230	3,165	1-5	.045
ABT8 ABT8V	.5000	1.0000	.500	.390	8	26,850	3,150	.25-8	.070
ABT9 ABT9V	.5625	1.0937	.562	.437	8	34,800	5,520	.25-8	.090
ABT10 ABT10V	.6250	1.1875	.625	.500	8	45,750	7,080	.25-8	.120
ABT12 ABT12V	.7500	1.4375	.750	.593	8	69,600	10,125	1-5	.210
ABT14 ABT14V	.8750	1.5625	.875	.703	8	93,300	14,025	2-8	.270
ABT16 ABT16V	1.0000	1.7500	1.000	.797	9	120,300	18,240	2-8	.390

*Ball width tolerance +.000 -.005

Materials

DESIGNATION	BALL	LINER	RACE
ABT	440C CRES	TEFLON® fabric	17-4PH CRES
ABT-V	heat treated	permanently bonded	heat treated
ATB		to race I.D.	

Staking Groove Data

BORE SIZES	LAND (S) +.000/- .010	GROOVE (X) +.000/- .010	RAD.(R) +.000/- .010	DEPTH (P) +.000/- .015
3 & 4	.020	.045	.015	.030
5 thru 7	.030	.055	.020	.040
8 thru 16	.030	.080	.020	.060

TEFLON® is a Du Pont registered trademark

SPHERICAL BEARINGS

ABWT, ABWT-V

TEFLON® Lined, Wide

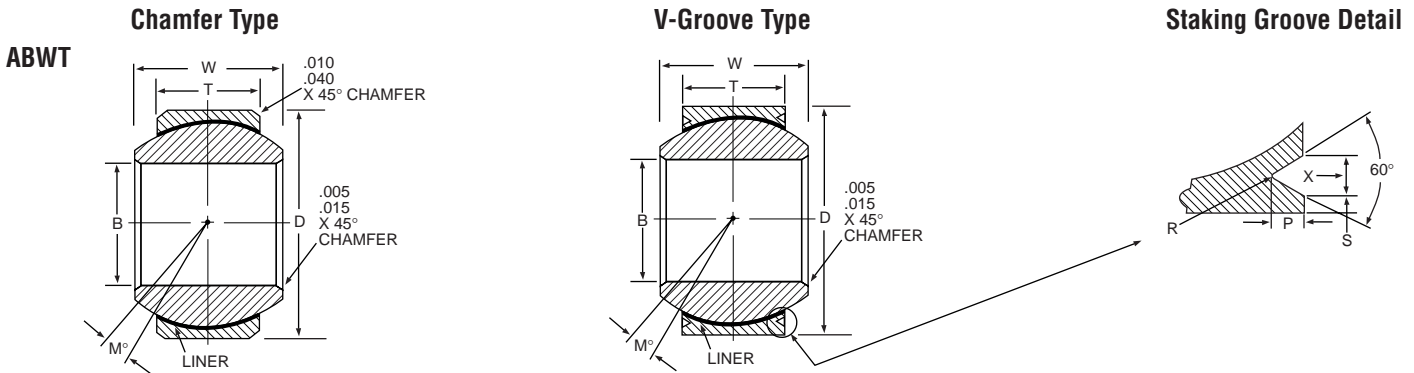

BASIC P/N	(B)	(D)	(W)	(T)	(M°)	ULT. STATIC RADIAL LOAD LBS.	ULT. STATIC AXIAL LOAD LBS.	NO LOAD ROTATIONAL BREAKAWAY TORQUE IN./LB.	APPROX. WEIGHT LBS.
	BORE DIA. +.0000 -.0005	OUTSIDE DIA. +.0000 -.0005	BALL WIDTH +.000 -.002	RACE WIDTH +/- .005	MIS-ALIGN. MIN.				
ABWT3 ABWT3V	.1900	.6250	.437	.327	15	6,120 [†]	2,655	.25-8	.031
ABWT4 ABWT4V	.2500	.6250	.437	.327	15	10,600 [†]	2,655	.25-8	.031
ABWT5 ABWT5V	.3125	.6875	.437	.317	14	14,100	2,460	.25-8	.035
ABWT6 ABWT6V	.3750	.8125	.500	.406	8	20,550	3,945	.25-8	.060
ABWT7 ABWT7V	.4375	.9375	.562	.442	10	31,050	5,475	.25-8	.080
ABWT8 ABWT8V	.5000	1.0000	.625	.505	9	41,250	7,455	.25-8	.100
ABWT9 ABWT9V	.5625	1.1250	.687	.536	10	51,600	8,055	.25-8	.135
ABWT10 ABWT10V	.6250	1.1875	.750	.567	12	58,500	9,195	.25-8	.160
ABWT12 ABWT12V	.7500	1.3750	.875	.630	13	78,450	11,595	.25-8	.240
ABWT14 ABWT14V	.8750	1.6250	.875	.755	6	100,950	16,200	.25-12	.350
ABWT16 ABWT16V	1.0000	2.1250	1.375	1.005	12	189,800	28,950	.25-12	.970

[†] Based on pin limitation using 108 KSI shear strength pin.

Materials

DESIGNATION	BALL	LINER	RACE
ABWT ABWT-V	440C CRES heat treated	TEFLON® fabric permanently bonded to race I.D.	17-4PH CRES heat treated

Staking Groove Data

BORE SIZES	LAND (S) +.000/- .010	GROOVE (X) +.000/- .010	RAD. (R) +.000/- .010	DEPTH (P) +.000/- .015
3 thru 5	.020	.045	.015	.030
6 thru 10	.030	.055	.020	.040
12 thru 16	.030	.080	.020	.060

TEFLON® is a Du Pont registered trademark



ABYT, ABYT-V

High Misalignment, TEFLON® Lined

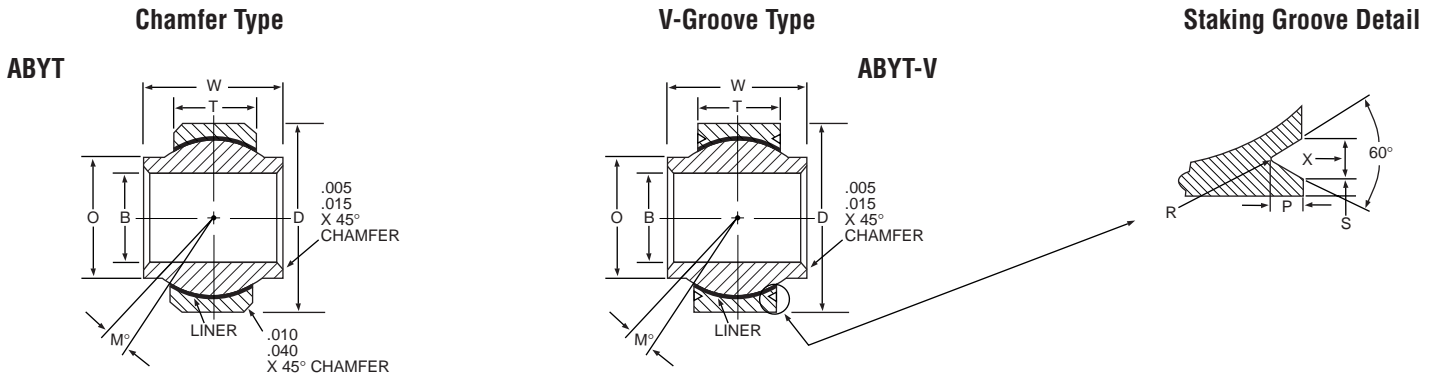

BASIC P/N	(B)	(D)	(W)	(T)	(O)	(M°)	ULT. STATIC RADIAL LOAD LBS.	ULT. STATIC AXIAL LOAD LBS.	NO LOAD ROTATIONAL BREAKAWAY TORQUE IN./LB	APPROX. WEIGHT LBS
	BORE DIA. +.0000 -.0005	OUTSIDE DIA. +.0000 -.0005	BALL WIDTH +.000 -.002	RACE WIDTH +/- .005	SHOULDER DIA. REF.	MIS-ALIGN. MIN.				
ABYT3 ABYT3V	.1900	.5625	.500	.210	.319	15	6,120 [†]	525	.5-5	.018
ABYT4 ABYT4V	.2500	.7400	.593	.255	.390	24	10,600 [†]	675	1-5	.036
ABYT5 ABYT5V	.3125	.6875	.625	.255	.418	20	13,500	675	1-5	.025
ABYT6 ABYT6V	.3750	.9060	.813	.345	.512	23	24,000	3,000	1-5	.068
ABYT7 ABYT7V	.4375	1.0000	.875	.345	.618	22	28,950	3,000	1-5	.095
ABYT8 ABYT8V	.5000	1.1250	.937	.401	.730	20	39,150	4,800	1-5	.159
ABYT10 ABYT10V	.6250	1.3750	1.200	.567	.856	20	66,750	10,500	1-5	.245
ABYT12 ABYT12V	.7500	1.5625	1.280	.620	.970	18	82,200	13,050	1-5	.315
ABYT14 ABYT14V	.8750	1.7500	1.400	.625	1.140	18	98,700	13,275	2-8	.430
ABYT16 ABYT16V	1.0000	2.1250	1.875	.835	1.278	21	162,000	23,850	2-8	.831

† Based on pin limitation using 108 KSI shear strength pin.

Materials

DESIGNATION	BALL	LINER	RACE
ABYT ABYT-V	440C CRES heat treated	TEFLON® fabric permanently bonded to race I.D.	17-4PH CRES heat treated

Staking Groove Data

BORE SIZES	LAND (S) +.000/- .010	GROOVE (X) +.000/- .010	RAD.(R) +.000/- .010	DEPTH (P) +.000/- .015
3 thru 8	.020	.045	.015	.030
10	.030	.055	.020	.040
12 thru 16	.030	.080	.020	.060

TEFLON® is a Du Pont registered trademark

STAKING PROCEDURE

Installation

1. Install bearing into housing per figure 1 and position it symmetrical about housing centerline within .005 (.13mm).
2. Mount bearing and top anvil over bottom anvil guide pin as shown in figure 2.
3. A trial assembly should be made for each new bearing lot to determine the staking force necessary to meet the axial retention load required. Excessive force should be avoided since this may result in bearing distortion and seriously impair bearing function and life.
4. Apply the the staking force established by trial assembly, rotate assembly 90° and re-apply force. Repeat procedure for opposite side of bearing.
5. After staking, a slight gap may exist between race lip and housing chamfer as shown in detail in figure 2. This gap should not be a cause for rejection providing the bearing meets the thrust load specified.

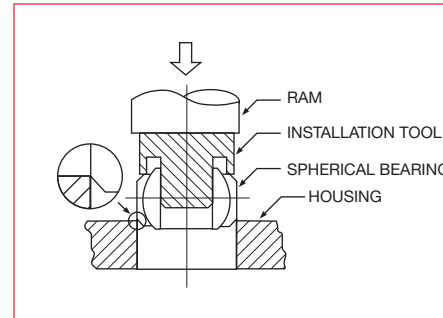

FIGURE 1– Spherical bearing installation.

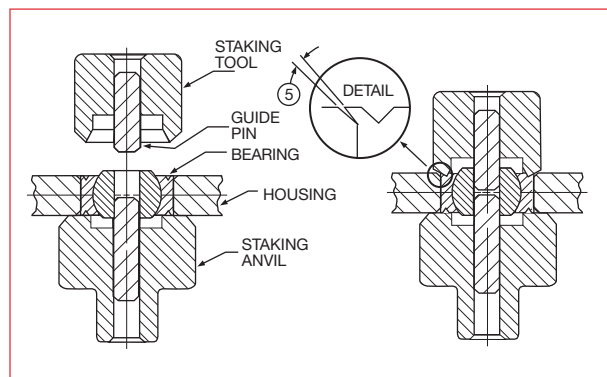

FIGURE 2– V-groove staking method.

Ordering Information:

Anvil staking tools can be furnished for all NHBB standard and special spherical bearings with staking grooves. A staking tool set consists of one staking (flaring) tool and one staking anvil, both with guide pins installed.



Misalignment Angle

Note:

Since angle "A" applies equally on both sides of the centerline, it follows that total misalignment of the bearing is double the value obtained for "A".

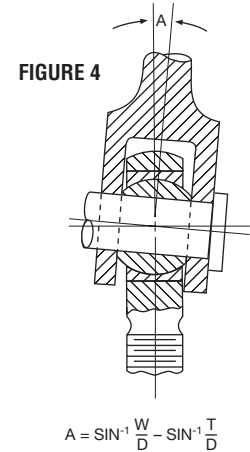
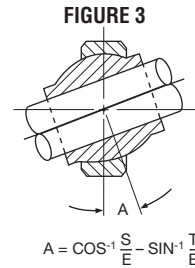
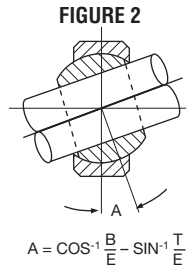
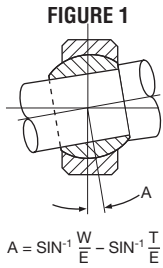

Standard Method

Most standard rod end & spherical bearing misalignment angles specified in NHBB catalog are based on this method.

Design Reference

This method may be used as design reference for installation purposes, but should not be used as a functioning misalignment under load.

High Misalignment Series Method (Neck balls only)

Rod End Clevis Misalignment

The misalignment angle of a rod end or spherical bearing refers to the angle between the ball centerline and the outer member centerline when the ball is misaligned to the extreme position allowed by the clevis or shaft design, as applicable. Figures 1 through 4 illustrate bearing misalignment and a formula for calculating each.

- A = Angle of Misalignment
- B = Bore of Ball
- D = Head Diameter (Rod End)
- E = Ball Spherical Diameter
- S = Shoulder Diameter (Neck Ball)
- T = Housing (Race) Width
- W = Width of Ball

Interchange Chart

Note:

This interchange chart shows approximate equivalency. It is not intended to indicate that all manufacturers' products are functionally interchangeable in all applications.

NHBB	ROSE	GOLDLINE/AMPEP	AURORA
ABT	RNR	11BNZ	PNB-T
ABT-V	RNRG	11BNG	PNB-TG
ABWT	RWR	11BWZ	PWB-T
ABWT-V	RWRG	11BWG	PWB-TG
ABYT	RA	—	—
ABYT-V	RAG	—	—
ARHT-ECR	RMR-U	22AMR-U2	PRXM-T
ARHT-CR	—	—	—
ART-ECR	RMRR-UJ	22AMR-U1	PRM-T
ART-CR	RFRR-UJ	—	—
ARYT-ECR	RMARR-U	22HMR-U2	HXAM-T
ARYT-CR	—	—	—